

heavy duty edition 2

hydrostar pumps

2860 rpm from Certikin

Standard Features - Hydrostar Pumps

- Composite plastic construction
- IP55 protection rating
- 2860 rpm
- 380 / 415 V - 50Hz
- Suction and discharge 3" socket

Design improvements may invalidate the dimensions. Latest drawings are available on request

- All dimensions are in mm

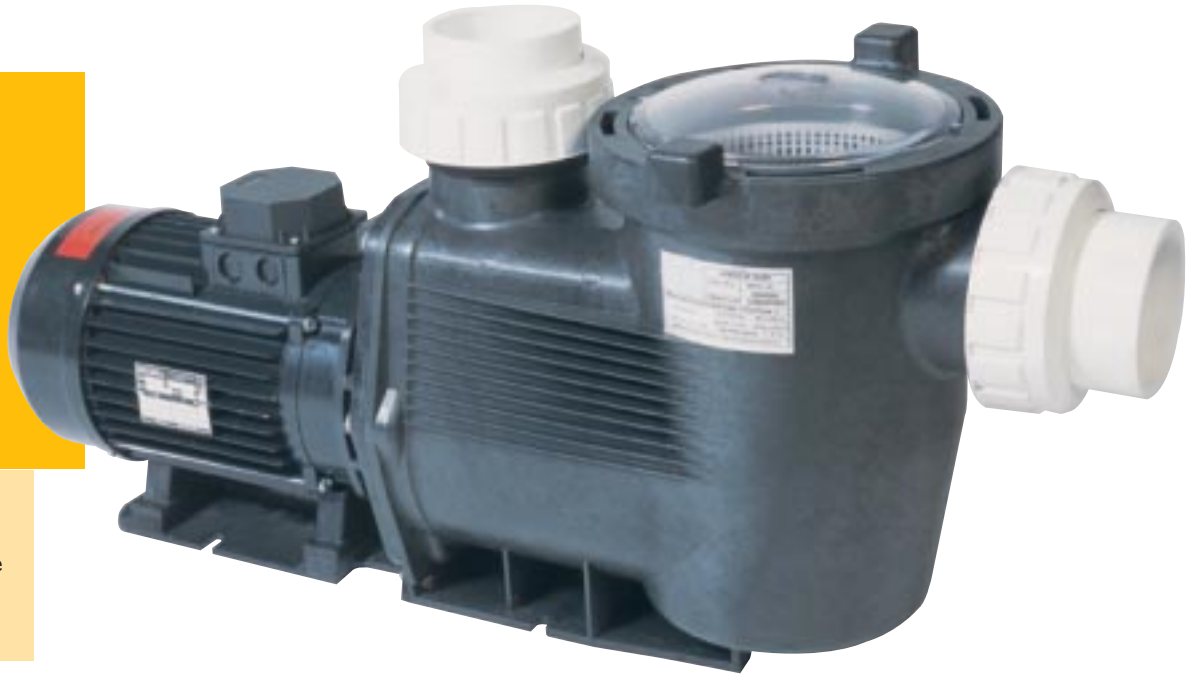

Certikin Hydrostar Commercial Pumps - 2860rpm

Code	Phase	Description	Running Current	Head (m)								Total Length	Motor Length	
				5	8	10	12	14	16	18	20			21
WHSR043	3	4.0HP (3.0kW)	5.8 AMP	51.6	46.8	42.0	36.6	29.0	24.0	7.20	-	-	834mm	100mm
WHSR053	3	5.0HP (3.75kW)	6.0 AMP	58.0	54.0	48.6	43.2	30.5	29.0	12.0	-	-	834mm	100mm
WHSR063	3	6.0HP (4.5kW)	7.2 AMP	61.5	58.8	55.2	48.0	42.5	33.5	26.8	7.8	-	834mm	100mm
WHSR073	3	7.0HP (5.25kW)	8.3 AMP	66.0	63.0	60.0	54.0	48.0	35.0	28.0	13.5	6.0	834mm	100mm

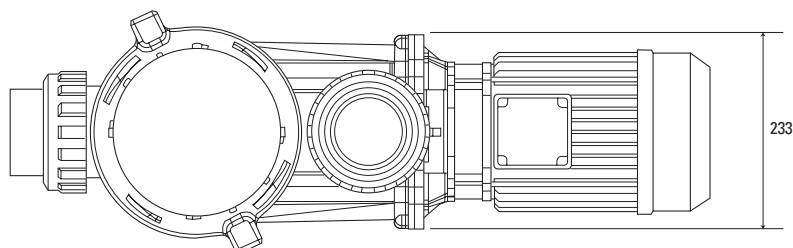
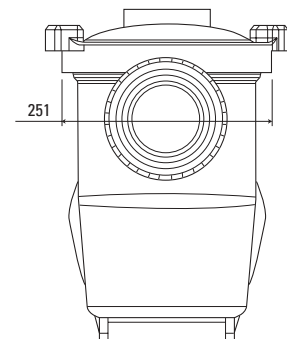
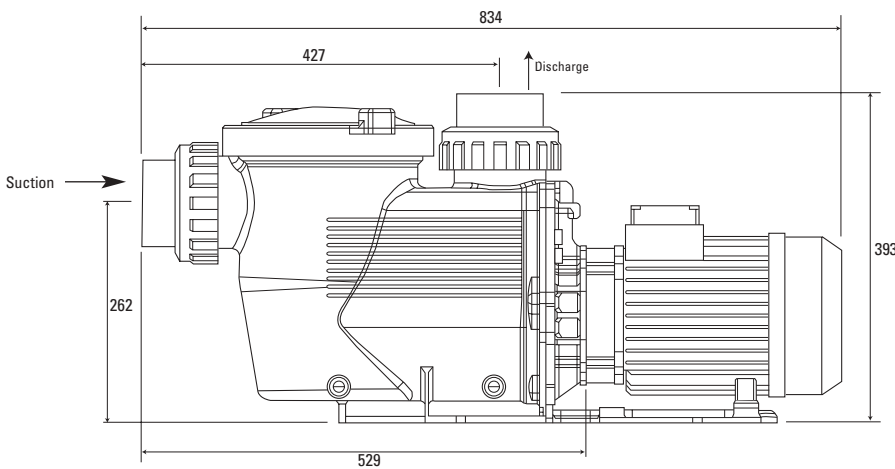

heavyduty

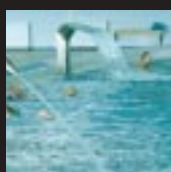
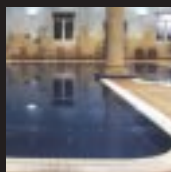
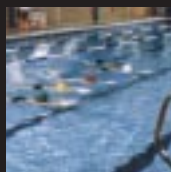
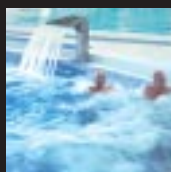
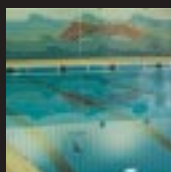
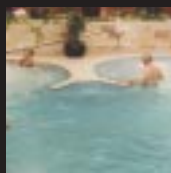
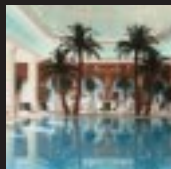
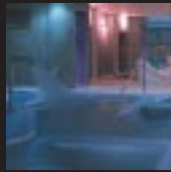

Certikin
international ltd

Certikin International
Witan Park,
Avenue 2,
Station Lane Industrial Estate, Witney,
Oxon OX28 4FJ

UK Tel: +44 (0) 1993 778855
UK Fax: +44 (0) 1993 778869
Export Tel: +44(0) 1993 700744
Export Fax: +44 (0) 1993 708499
E-mail: info@certikin.co.uk
Web: <http://www.certikin.co.uk>